

| REVISIONS | | | | |
|-----------|-----|-------------------------|-----------|-------|
| P. | LTN | DESCRIPTION | DATE | APVD |
| B3 | | ADD NEW DASH NUMBER -16 | 24APR2014 | CZ SZ |
| | | | | |
| | | | | |

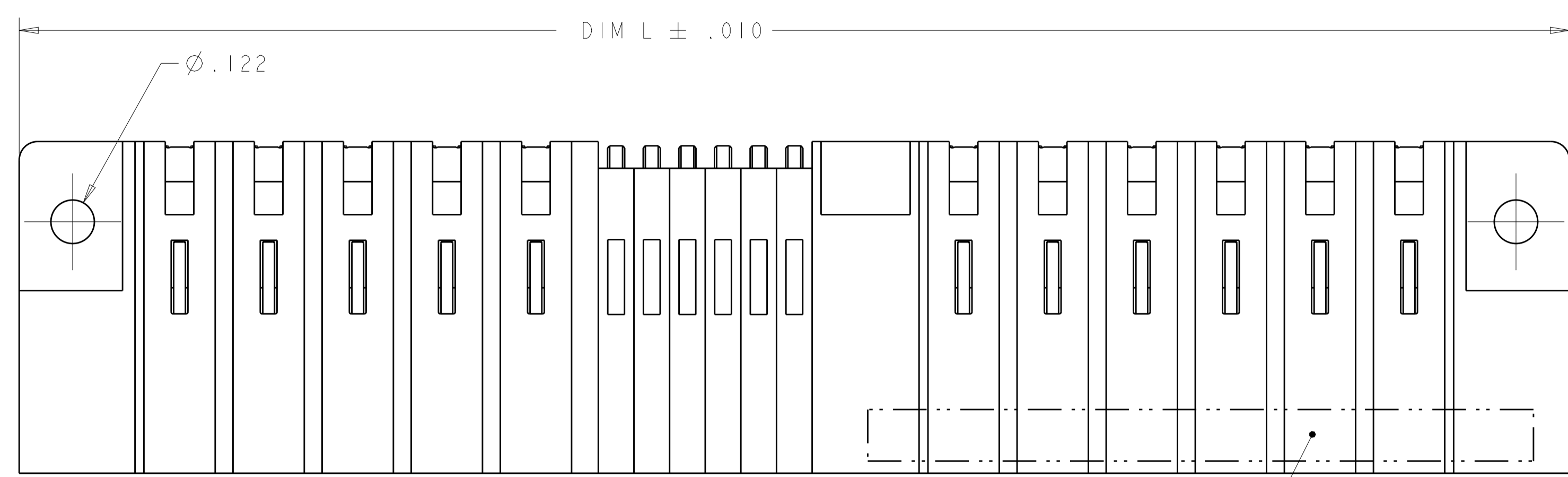

- 1 "AMP", PART NUMBER, AND DATE CODE TO BE MARKED IN AREA SHOWN
- 2 MATERIAL: HOUSING - GLASS FILLED HIGH TEMP THERMO PLASTIC, UL94 V-0
 SIGNAL CONTACT - COPPER ALLOY
 POWER CONTACT - HIGH CONDUCTIVITY COPPER ALLOY
- 3 CONTACT PLATING: NOBLE METAL PLATING ON CONTACT FUNCTIONAL AREA OF POWER AND SIGNAL CONTACTS
- 4 MECHANICAL CONNECTOR KEEP OUT ZONE.
- 5 DATUM AND BASIC DIMENSIONS ESTABLISHED BY CUSTOMER.
- 6 PCB - ALL HOLE DIAMETERS ARE FINISHED HOLE SIZES
- 7 PCB - .0453 ± .0010 DRILLED HOLES PLATED WITH .0003 MIN Sn OVER .001-.003 CU PLATING TO ACHIEVE .040 ± .003 DIAMETER HOLE
- 8 VARIABLE DIMS SHOWN ON VIEW (SHEET 2)
- 9 NOT RELEASED FOR PRODUCTION

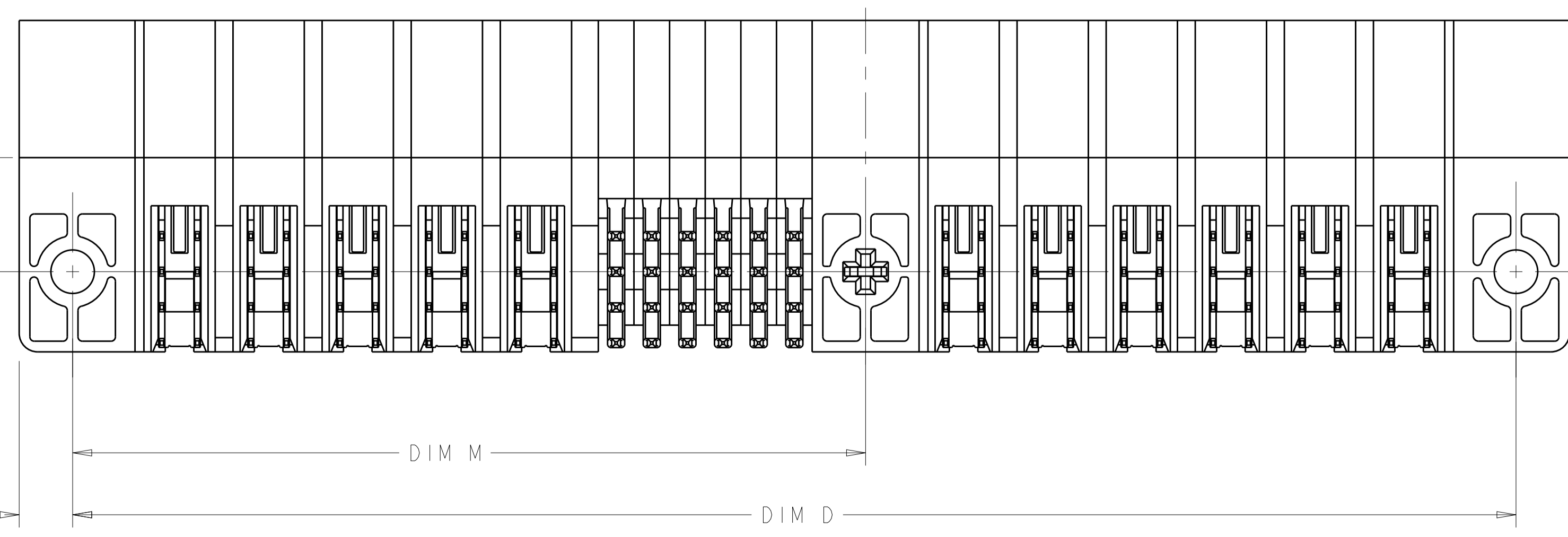
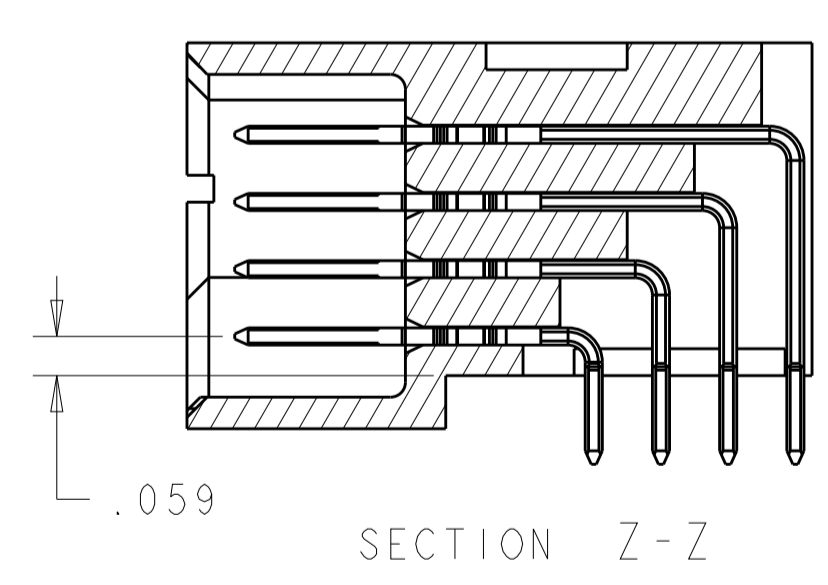
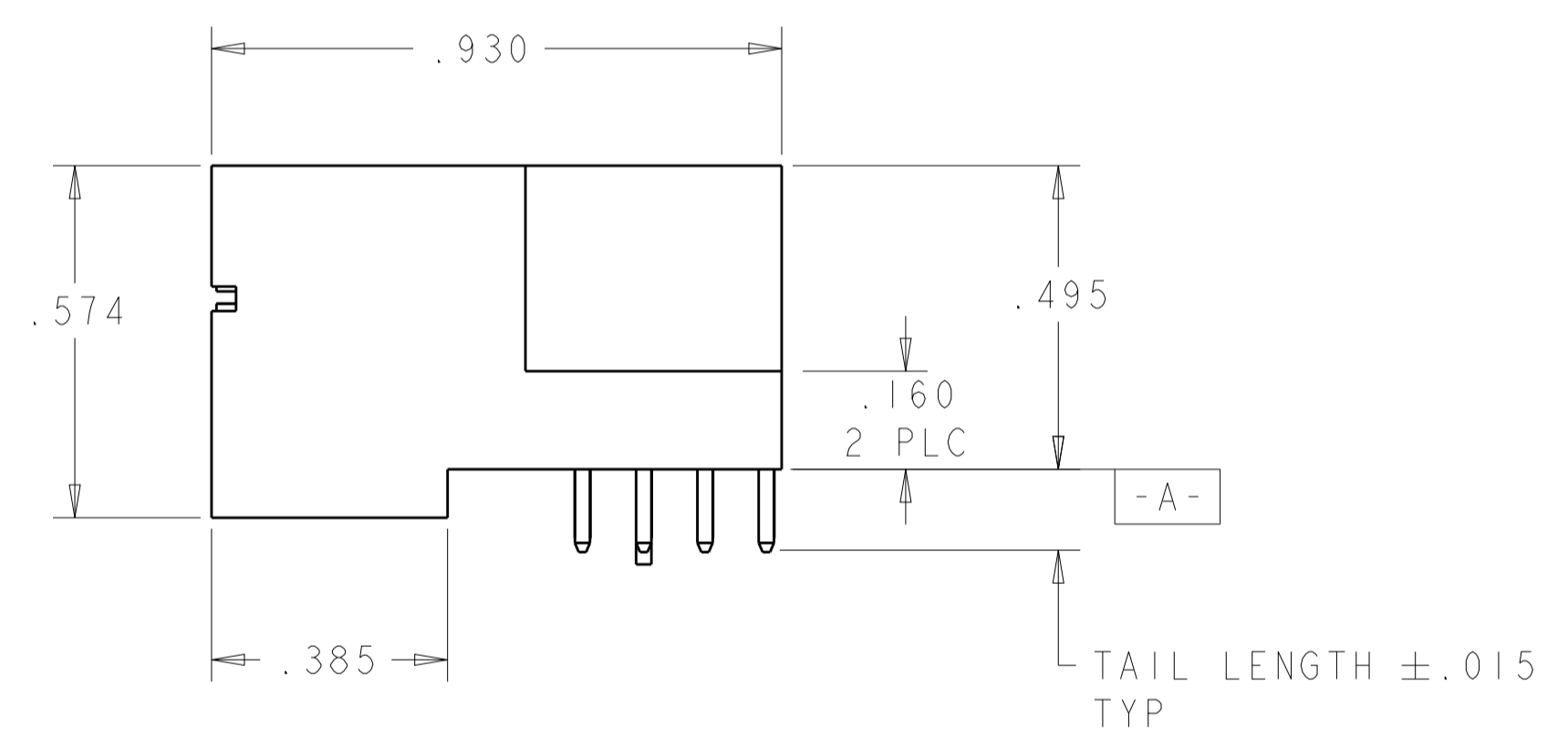
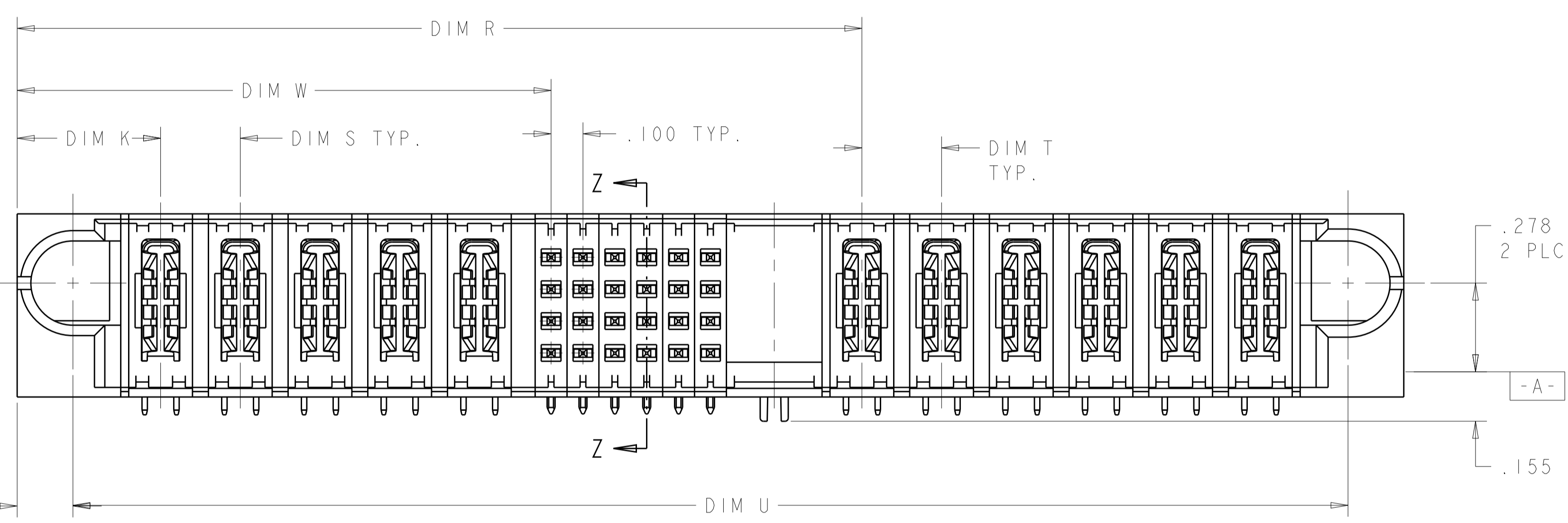

| | | | | |
|--|---|--|--|-----------------|
| THIS DRAWING IS A CONTROLLED DOCUMENT. | | DWN: R.GRZYBOWSKI 22FEB05 CHK: M.PERCHEK 22FEB05 APVD: M.PERCHEK PRODUCT SPEC: 108-1973 APPLICATION SPEC: 114-13038 WEIGHT: - CUSTOMER DRAWING | NAME: RIGHT ANGLE SOLDER HEADER ASSEMBLY MULTI-BEAM XL SIZE: A1 SCALE: 7:2 SHEET: 1 OF 6 REV: B3 | TE Connectivity |
| DIMENSIONS: INCHES | TOLERANCES UNLESS OTHERWISE SPECIFIED: 0 PLC ±. 1 PLC ±.01 2 PLC ±.005 3 PLC ±.0020 ANGLES ±.2° FINISH: | RESTRICTED TO: | | |

THIS DRAWING IS UNPUBLISHED. RELEASED FOR PUBLICATION 20
 © COPYRIGHT 20 BY - ALL RIGHTS RESERVED.

| REVISIONS | | | | |
|-----------|-----|-------------|------|------|
| P. | LTN | DESCRIPTION | DATE | APVD |
| - | | SEE SHEET 1 | - | - |
| | | | | |
| | | | | |

| | | | | | | | | | | |
|-------|-------|-------|-------|-------|-------|-------|-------|-------|----------------------|-------------|
| 2.750 | .250 | - | 2.650 | 1.375 | 2.800 | - | 3.100 | .450 | 4P + 48S + 1P | I-6450230-6 |
| 5.150 | .300 | .300 | 3.550 | 2.700 | 5.200 | - | 5.500 | .450 | 8ACP + 32S + 6ACP | I-6450230-5 |
| 2.300 | .300 | .250 | 1.950 | 1.275 | 2.350 | - | 2.650 | .475 | 3ACP + 24S + 2P | 6450230-6 |
| 5.450 | .250 | .250 | 3.350 | 2.375 | 5.500 | - | 5.800 | .450 | 8P + 36S + 9P | 6450230-4 |
| 4.275 | .250 | .250 | 3.175 | 2.500 | 4.325 | - | 4.625 | .475 | 2ACP + 6P + 24S + 5P | 6450230-3 |
| 4.000 | .250 | .250 | 2.650 | 1.675 | 4.050 | 2.225 | 4.350 | .450 | 5P + 24S + 1M + 6P | 6450230-2 |
| 4.000 | .250 | .250 | 2.650 | 1.675 | 4.050 | 2.225 | 4.350 | .450 | 5P + 24S + 1M + 6P | 6450230-1 |
| DIM U | DIM S | DIM T | DIM R | DIM W | DIM D | DIM M | DIM L | DIM K | DESCRIPTION | PART NUMBER |

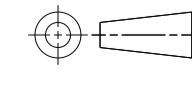
| | | | | |
|---|--|----------------------|---------------|---|
| THIS DRAWING IS A CONTROLLED DOCUMENT. | | DWN R. GRZYBOWSKI | 22FEB05 |  TE Connectivity |
| | | CHK M. PERCHERKE | 22FEB05 | |
| DIMENSIONS: INCHES | TOLERANCES UNLESS OTHERWISE SPECIFIED: | APVD M. PERCHERKE | NAME | RIGHT ANGLE SOLDER HEADER ASSEMBLY MULTI-BEAM XL |
|  | 0 PLC ± | PRODUCT SPEC | 108-1973 | |
| | 2 PLC ±.01 | APPLICATION SPEC | 114-13038 | |
| | 5 PLC ±.005 | FINISH | | |
| MATERIAL | FINISH | WEIGHT | RESTRICTED TO | |
| | | CUSTOMER DRAWING | SCALE 7:2 | SHEET 2 OF 6 |
| | | | REV B.3 | |

| REVISIONS | | | | |
|-----------|-------------|------|-----|------|
| P. LTH | DESCRIPTION | DATE | OWN | APVD |
| - | SEE SHEET 1 | - | - | - |

| PART NUMBER | ROWS | POWER | | | | | SIGNAL | | | | | | CM | POWER | | | | | |
|-------------|------------------|-------|----|----|----|----|--------|---|---|---|---|---|----|-------|----|----|----|-----|-----|
| | | P1 | P2 | P3 | P4 | P5 | 1 | 2 | 3 | 4 | 5 | 6 | | P6 | P7 | P8 | P9 | P10 | P11 |
| 6450230-1 | D C B A | PM | PM | PM | PM | PM | J | J | J | J | J | J | HD | PM | PM | PM | PM | PM | PM |
| | | PM | PM | PM | PM | PM | K | K | K | K | K | K | | PM | PM | PM | PM | PM | |
| | | PM | PM | PM | PM | PM | N | N | N | N | N | N | | PM | PM | PM | PM | PM | |
| | | PM | PM | PM | PM | PM | S | S | S | S | S | H | | PM | PM | PM | PM | PM | |

5P + 24S + 1M + 6P

| PART NUMBER | ROWS | POWER | | | | | | | | SIGNAL | | | | | | POWER | | | | | |
|-------------|------------------|-------|----|----|----|----|----|----|----|--------|---|---|---|---|----|-------|-----|-----|-----|-----|----|
| | | P1 | P2 | P3 | P4 | P5 | P6 | P7 | P8 | 1 | 2 | 3 | 4 | 5 | 6 | P9 | P10 | P11 | P12 | P13 | |
| 6450230-3 | D C B A | PM | PM | PM | PM | PM | PM | PM | PM | E | J | E | E | J | E | | PM | PM | PM | PM | PM |
| | | PM | PM | PM | PM | PM | PM | PM | K | K | F | K | K | K | PM | | PM | PM | PM | PM | |
| | | PM | PM | PM | PM | PM | PM | PM | N | N | N | G | N | N | PM | | PM | PM | PM | PM | |
| | | PM | PM | PM | PM | PM | PM | PM | H | S | H | H | S | H | PM | | PM | PM | PM | PM | |

2ACP + 6P + 24S + 5P

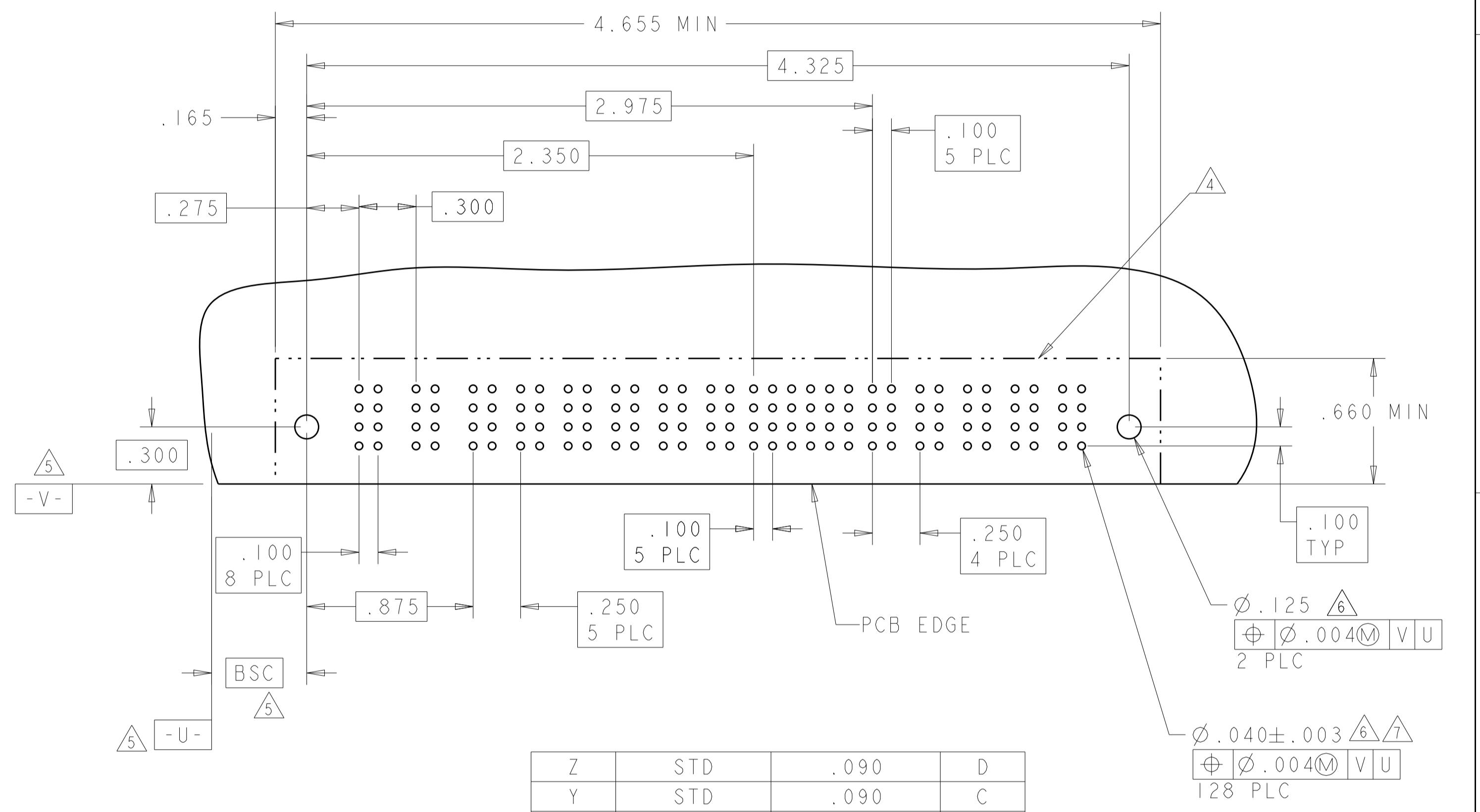
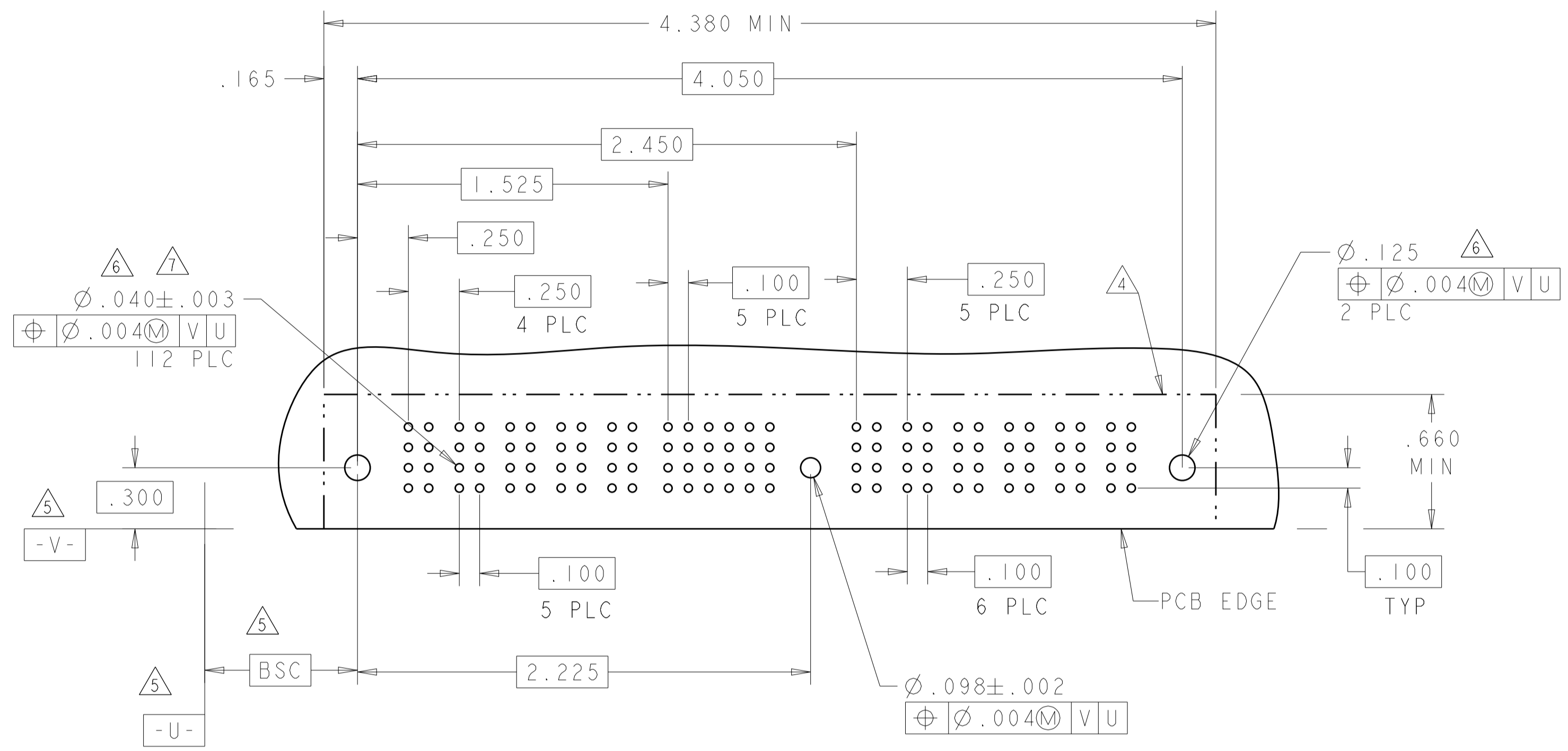

| PART NUMBER | ROWS | POWER | | | | | SIGNAL | | | | | | CM | POWER | | | | | |
|-------------|------------------|-------|----|----|----|----|--------|---|---|---|---|---|----|-------|----|----|----|-----|-----|
| | | P1 | P2 | P3 | P4 | P5 | 1 | 2 | 3 | 4 | 5 | 6 | | P6 | P7 | P8 | P9 | P10 | P11 |
| 6450230-2 | D C B A | PM | PM | PM | PM | PM | J | J | J | J | J | J | | PM | PM | PM | PM | PM | PM |
| | | PM | PM | PM | PM | PM | K | K | K | K | K | K | | PM | PM | PM | PM | PM | |
| | | PM | PM | PM | PM | PM | N | N | N | N | N | N | | PM | PM | PM | PM | PM | |
| | | PM | PM | PM | PM | PM | S | S | S | S | S | H | | PM | PM | PM | PM | PM | |

5P + 24S + 1M + 6P

| CODE | MATING SEQUENCE | TAIL LENGTH | ROW |
|------|-----------------|-------------|-----|
| Z | STD | .090 | D |
| Y | STD | .090 | C |
| R | STD | .090 | B |
| O | STD | .090 | A |
| A4 | MLBF | .090 | D |
| A3 | MLBF | .090 | C |
| A2 | MLBF | .090 | B |
| A1 | MLBF | .090 | A |
| E | MLBF | .135 | D |
| F | MLBF | .135 | C |
| G | MLBF | .135 | B |
| H | MLBF | .135 | A |
| J | STD | .135 | D |
| K | STD | .135 | C |
| N | STD | .135 | B |
| S | STD | .135 | A |

| CODE | TAIL LENGTH |
|------|-------------|
| PM | .135 |
| PA | .090 |

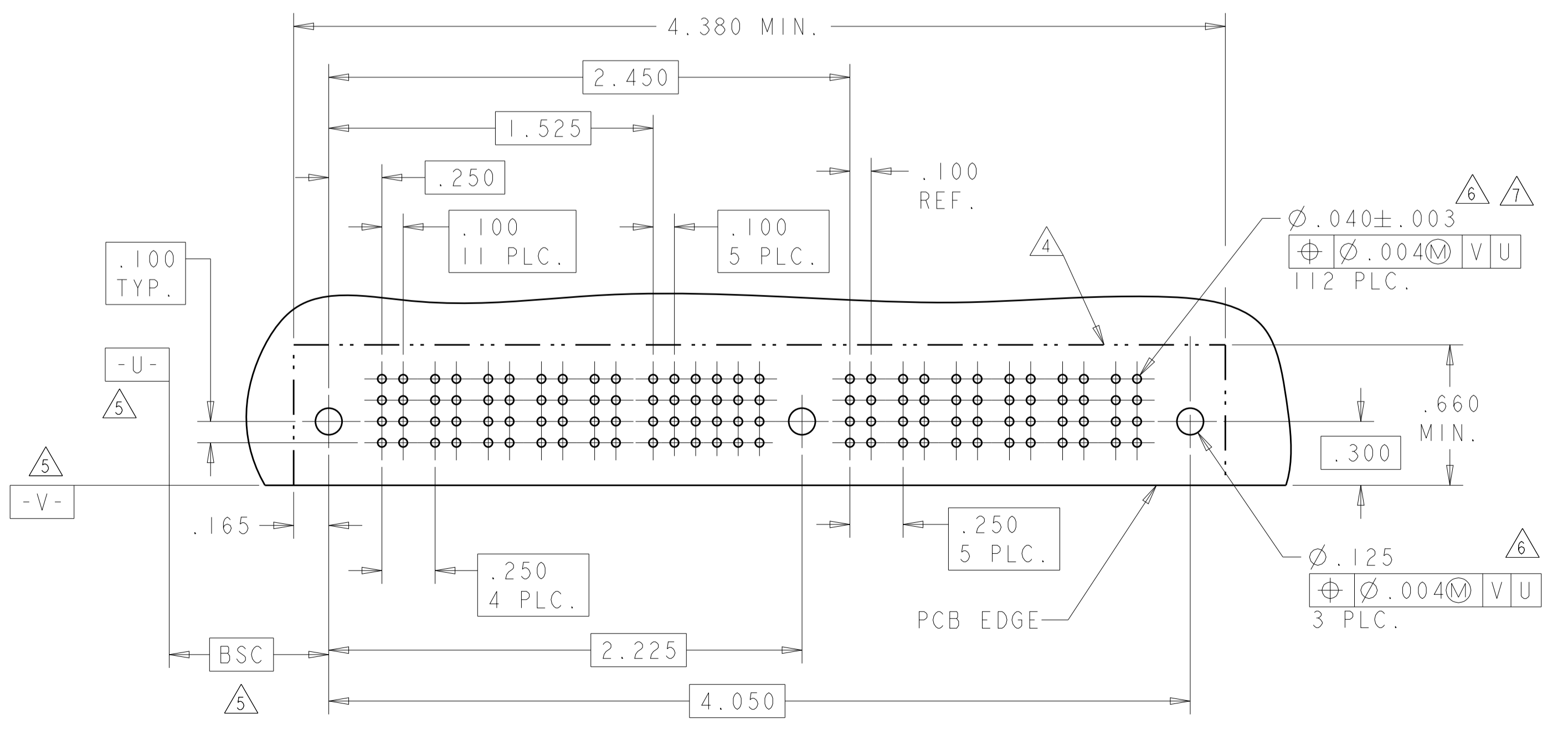

THIS DRAWING IS A CONTROLLED DOCUMENT. OWN: R. GRZYBOWSKI, 22FEB05. CHK: M. PERCHERKE, 22FEB05. APVD: M. PERCHERKE.

| | | | |
|--------------------|--|------------------|--|
| DIMENSIONS: INCHES | TOLERANCES UNLESS OTHERWISE SPECIFIED: | PRODUCT SPEC | NAME |
| 0 PLC ±.01 | 1 PLC ±.01 | 108-1973 | RIGHT ANGLE SOLDER HEADER ASSEMBLY MULTI-BEAM XL |
| 2 PLC ±.01 | 3 PLC ±.01 | APPLICATION SPEC | SIZE |
| 4 PLC ±.005 | ANGLES ±.0020 | 114-13038 | A1 |
| MATERIAL | FINISH | WEIGHT | CAGE CODE DRAWING NO |
| | | | 6450230 |
| | | CUSTOMER DRAWING | SCALE 4:1 SHEET 3 OF 6 REV B3 |

| REVISIONS | | | | |
|-----------|------|-------------|------|-------|
| P. | LTN. | DESCRIPTION | DATE | APVD. |
| - | - | SEE SHEET 1 | - | - |
| | | | | |
| | | | | |

| PART NUMBER | ROWS | POWER | | | | | | | | SIGNAL | | | | | | | | | POWER | | | | | | | | | | |
|---------------|------------------|-------|----|----|----|----|----|----|----|--------|---|---|---|---|---|---|---|---|-------|-----|-----|-----|-----|-----|-----|-----|-----|--|--|
| | | P1 | P2 | P3 | P4 | P5 | P6 | P7 | P8 | 1 | 2 | 3 | 4 | 5 | 6 | 7 | 8 | 9 | P9 | P10 | P11 | P12 | P13 | P14 | P15 | P16 | P17 | | |
| 6450230-4 | D C B A | PM | PM | PM | PM | PM | PM | PM | PM | J | J | J | J | J | J | J | E | J | PM | PM | PM | PM | PM | PM | PM | PM | PM | | |
| | | K | K | K | K | K | K | K | K | K | K | K | K | K | K | K | K | K | PM | PM | PM | PM | PM | PM | PM | PM | | | |
| | | N | N | N | N | N | N | N | N | N | N | N | N | N | N | N | N | N | PM | PM | PM | PM | PM | PM | PM | PM | | | |
| | | S | S | S | S | S | S | S | S | S | S | S | S | S | S | S | S | S | PM | PM | PM | PM | PM | PM | PM | PM | | | |
| 8P + 36S + 9P | | | | | | | | | | | | | | | | | | | | | | | | | | | | | |

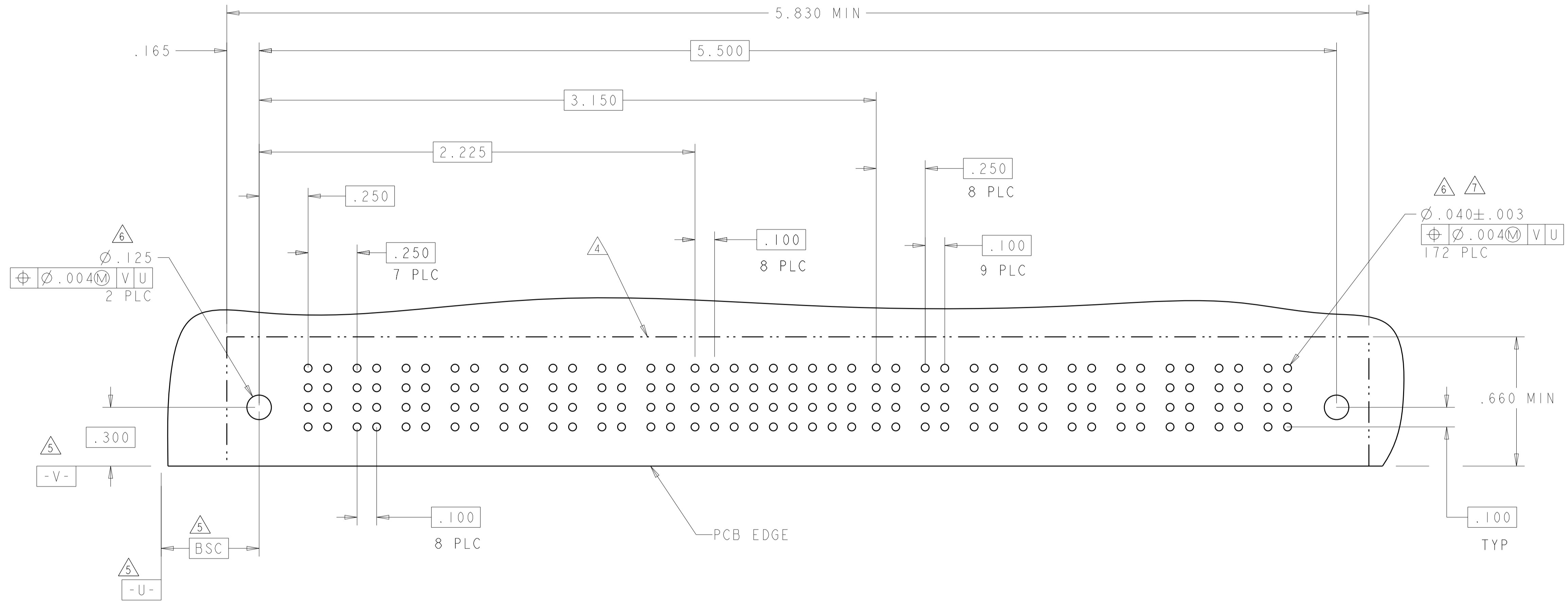

| | | | | |
|--|--|--|--------------------|-------------------------|
| THIS DRAWING IS A CONTROLLED DOCUMENT. | | OWN R. GRZYBOWSKI CHK M. PERCHERKE APVD M. PERCHERKE | 22FEB05 22FEB05 | TE Connectivity |
| DIMENSIONS: INCHES | | TOLERANCES UNLESS OTHERWISE SPECIFIED: 0 PLC ±. 1 PLC ±. 2 PLC ±.01 3 PLC ±.005 4 PLC ±.0020 ANGLES ±.7° FINISH | | |
| | | MATERIAL FINISH | | SIZE A1 |
| MATERIAL | | WEIGHT | | CAGE CODE 6450230 |
| CUSTOMER DRAWING | | SCALE 7:2 | | SHEET 4 OF 6 REV B.3 |

| REVISIONS | | | | |
|-----------|-----|-------------|------|------|
| P | LTN | DESCRIPTION | DATE | APVD |
| - | - | SEE SHEET 1 | - | - |
| | | | | |
| | | | | |

| PART NUMBER | ROWS | POWER | | | SIGNAL | | | | | | POWER | |
|-----------------|------------------|-------|----|----|--------|---|---|---|---|---|-------|----|
| | | P1 | P2 | P3 | 1 | 2 | 3 | 4 | 5 | 6 | P4 | P5 |
| 6450230-6 | D C B A | PM | PM | PM | J | J | J | J | J | J | PM | PM |
| | | | | | K | K | K | K | K | K | | |
| | | | | | N | N | N | N | N | N | | |
| 3ACP + 24S + 2P | | | | | S | S | S | S | S | S | | |

| PART NUMBER | ROWS | POWER | | | | SIGNAL | | | | | | | | POWER | | | | | | | |
|---------------|------|-------|----|----|----|--------|---|---|---|---|---|---|---|-------|----|----|----|----|--|--|--|
| | | P1 | P2 | P3 | P4 | 1 | 2 | 3 | 4 | 5 | 6 | 7 | 8 | 9 | 10 | 11 | 12 | P4 | | | |
| 1-6450230-6 | D | PM | PM | PM | PM | E | | | E | J | J | J | E | | | | | | | | |
| | C | | | | | F | F | F | F | | K | K | F | F | | | | | | | |
| | B | | | | | G | | | | N | N | N | G | N | | | | | | | |
| | A | | | | | H | H | H | H | H | | S | H | H | | | | | | | |
| 4P + 48S + 1P | | | | | | | | | | | | | | | | | | | | | |

BLANK SIGNAL PINS ARE UNLOADED PINS

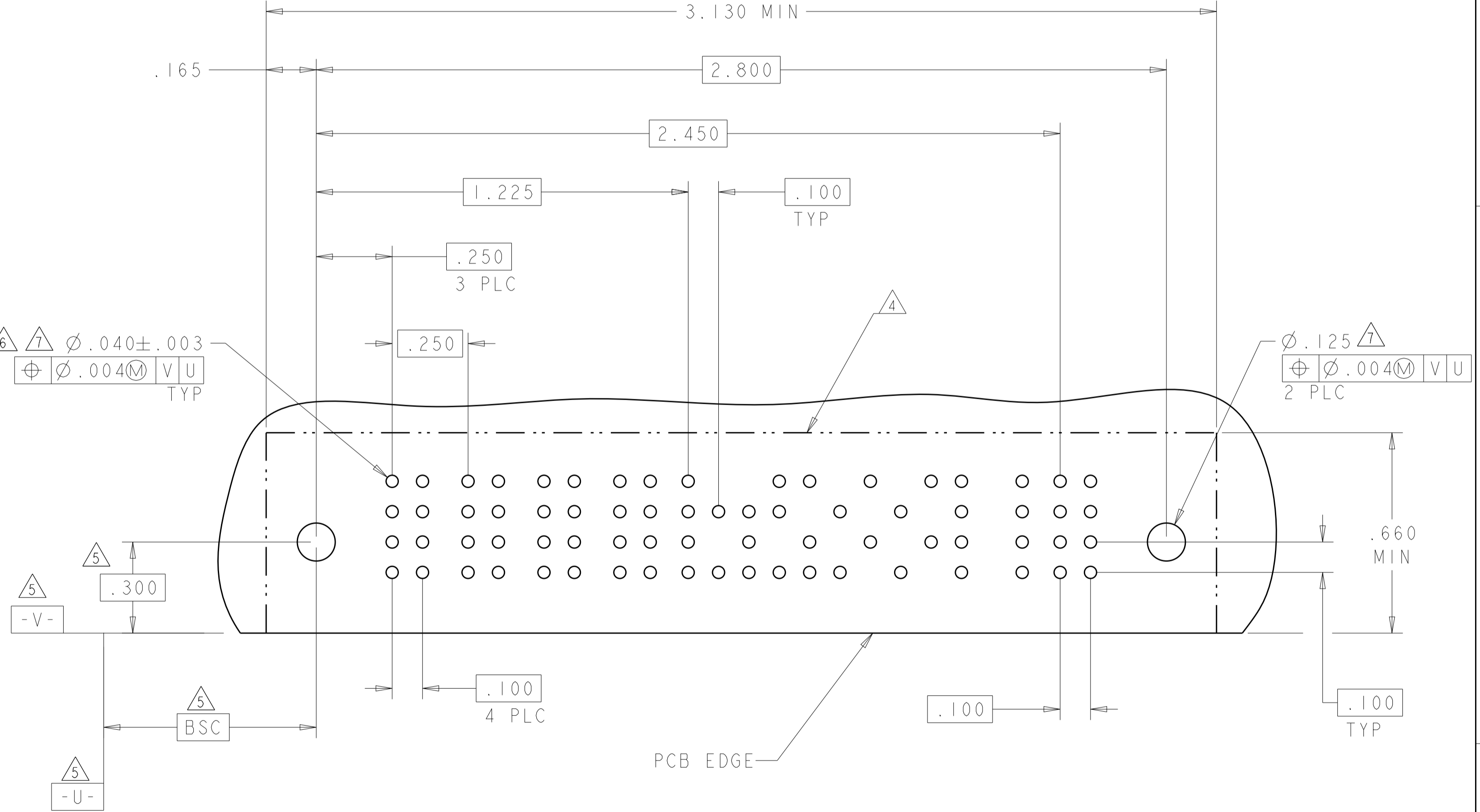
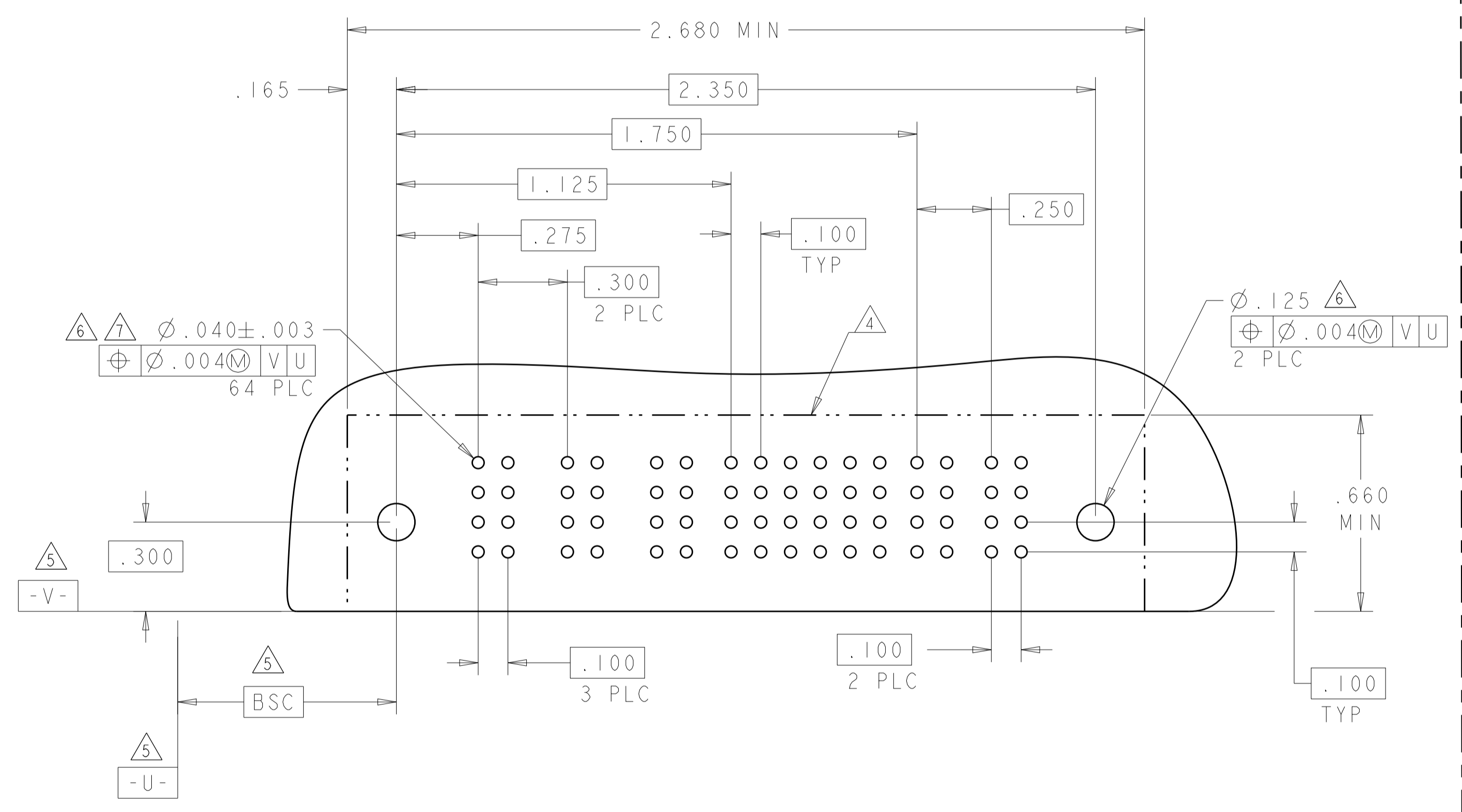

| | | | | |
|--|--------|---|----------------------|----------------------------|
| THIS DRAWING IS A CONTROLLED DOCUMENT. | | DWN R. GRZYBOWSKI 22FEB05 | 22FEB05 | STE TE Connectivity |
| DIMENSIONS: INCHES | | CHK M. PERCHERKE | APVD M. PERCHERKE | |
| TOLERANCES UNLESS OTHERWISE SPECIFIED: | | NAME RIGHT ANGLE SOLDER HEADER ASSEMBLY MULTI-BEAM XL | | RESTRICTED TO |
| 0 PLC ± .01 2 PLC ± .01 3 PLC ± .005 4 PLC ± .002 ANGLES ± .2° | | PRODUCT SPEC 108-1973 APPLICATION SPEC 114-13038 | | |
| MATERIAL | FINISH | WEIGHT | SIZE A1 | CAGE CODE 6450230 |
| CUSTOMER DRAWING | | SCALE 7:2 | SHEET 5 OF 6 | REV B3 |

| REVISIONS | | | | |
|-----------|------|-------------|------|-------|
| P. | LTN. | DESCRIPTION | DATE | APVD. |
| - | - | SEE SHEET 1 | - | - |
| | | | | |
| | | | | |

| PART NUMBER | ROWS | POWER | | | | | | | | SIGNAL | | | | | | | | POWER | | | | | |
|-------------------|------------------|-------|----|----|----|----|----|----|----|--------|---|---|---|---|---|---|---|-------|-----|-----|-----|-----|-----|
| | | P1 | P2 | P3 | P4 | P5 | P6 | P7 | P8 | 1 | 2 | 3 | 4 | 5 | 6 | 7 | 8 | P9 | P10 | P11 | P12 | P13 | P14 |
| 1-6450230-5 | D C B A | PM | PM | | PM | PM | | PM | | J | J | J | J | J | J | J | J | | PM | PM | | PM | PM |
| | | | | | | | | | | K | K | K | K | K | K | K | K | | | | | | |
| | | | | | | | | | | N | N | N | N | N | N | N | N | | | | | | |
| 8ACP + 32S + 6ACP | | | | | | | | | | H | S | S | S | S | S | S | | | | | | | |

NO CONTACT LOADED

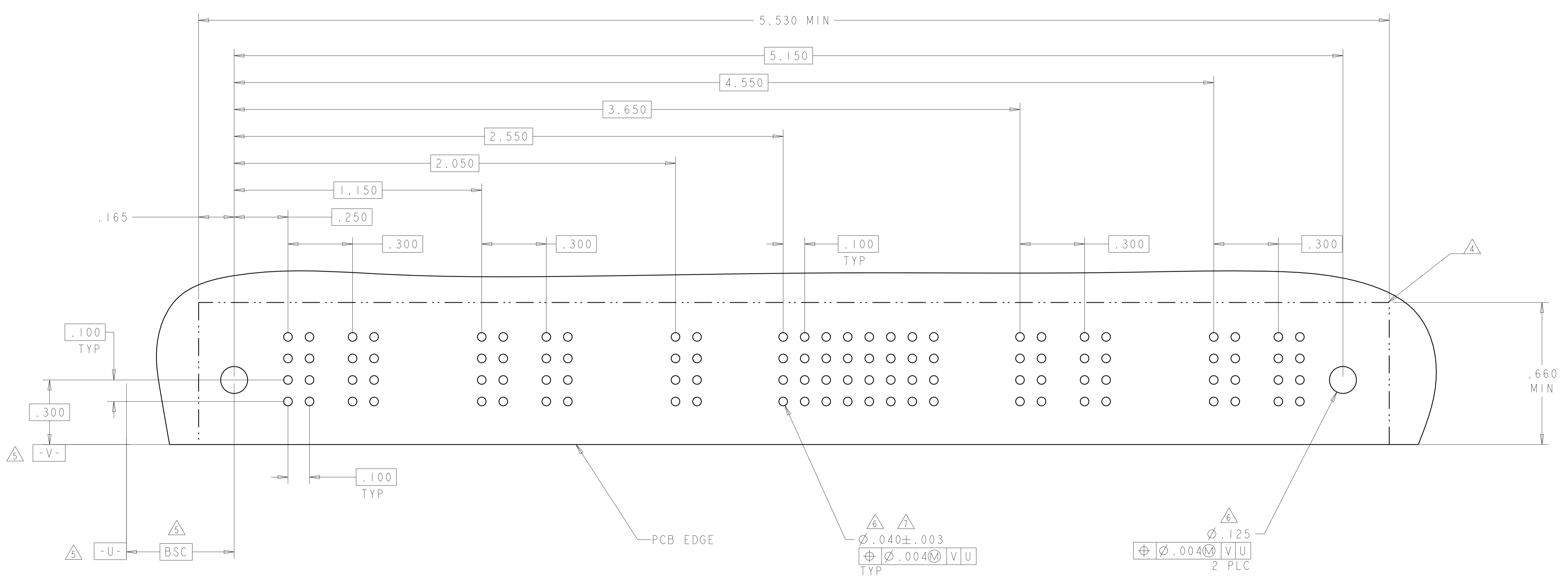

| | | | |
|---|--|-----------------------------|--|
| THIS DRAWING IS A CONTROLLED DOCUMENT. | | OWN: R. GRZYBOWSKI 22FEB05 | TE Connectivity |
| DIMENSIONS: INCHES | | CHK: M. PERCHERKE 22FEB05 | |
| TOLERANCES UNLESS OTHERWISE SPECIFIED: 0 PLC ±. 1 PLC ±.01 2 PLC ±.005 3 PLC ±.002 4 PLC ±.0020 ANGLES ±.2° | | APVD: M. PERCHERKE | NAME: RIGHT ANGLE SOLDER HEADER ASSEMBLY MULTI-BEAM XL |
| MATERIAL: - | | PRODUCT SPEC: 108-1973 | SIZE: A1 |
| FINISH: - | | APPLICATION SPEC: 114-13038 | CAGE CODE: - |
| CUSTOMER DRAWING | | WEIGHT: - | DRAWING NO: C=6450230 |
| SCALE: 7:2 | | SHEET: 6 OF 6 | REV: B.3 |